

GROTE COMPANY FAMILY OF BRANDS



**HYGIENIC RESTORATION
SLICING: GOOD, BETTER, BEST**

TO FEED OUR GROWING WORLD - TOGETHER

Hygienic design has advanced in the last 30 years—but you still have **legacy slicers that impact your daily sanitation.**



Learn the **outdated features** impacting your operation, where to **restore and improve existing equipment**, and when to **invest in the latest designs.**



About Me

Brad Eley

Engineering Manager, Grote Company

- Education
 - University of Dayton: Bachelors in Mechanical Engineering
 - Eastern University: Masters in Business Administration
- Career Building for the last 13 years
 - AESI: Project Manager
 - Ryder Last Mile: IT project Manager



Agenda

- Good – Currently in Plants
- Better – Improve Existing Equipment
- Best – New Equipment Options
- How do we improve?
- Q&A



GOOD

Legacy equipment in your plants works for your operation but outdated sanitary design increases downtime and risk of contamination issues.



Good – Currently in Plants

- Limited Accessibility
- Low IP Rated Components
- Structural Construction Concerns: Hollow Tubing



Good – Currently in Plants



Good – Currently in Plants



BETTER

Work with your OEM to find areas to **modify**
legacy equipment to improve sanitation.



Better – Improve Existing Equipment

- Field Service Assessments
- Field Modifications of Equipment
- Routine vs Periodic Sanitation



Better – Improve Existing Equipment: Sanitation Carts

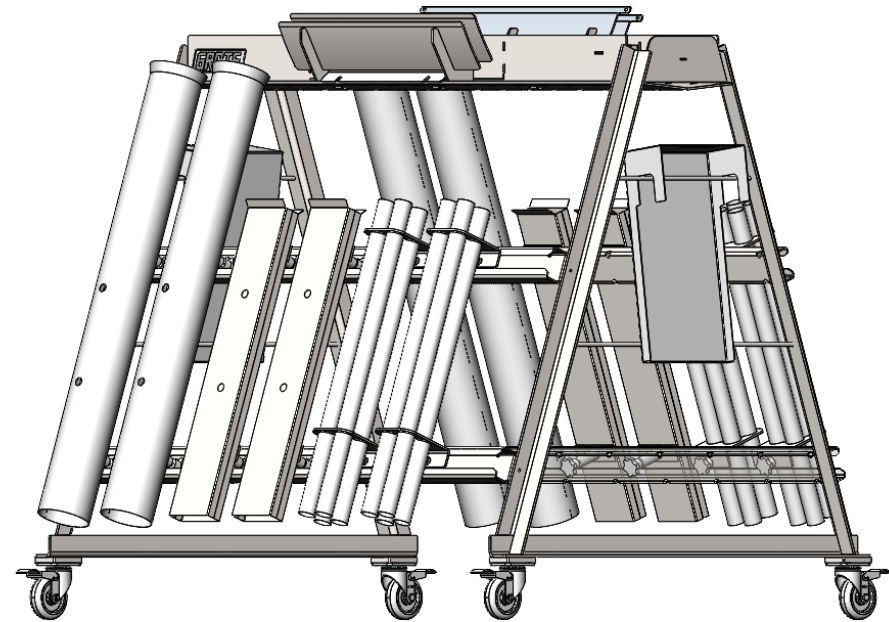
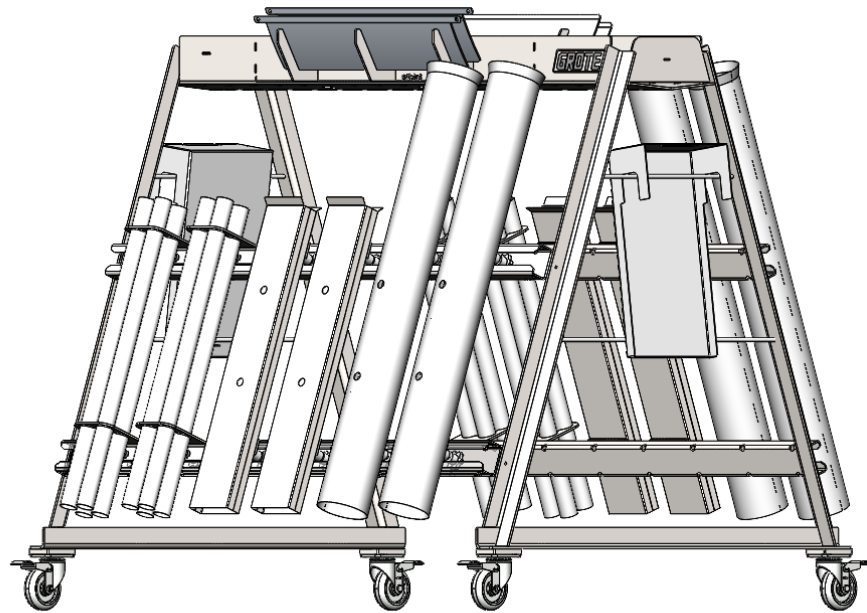

Better – Improve Existing Equipment: Routine/Periodic



BEST

Replace legacy equipment with the latest models designed with **modern sanitation design standards.**



Best – New Equipment Improvements

- Accessibility Improvements
- High IP Rated Components
- Structure: Open Frame or Solid Bar
- Toolless Removal of Components



Best – New Equipment Improvements: Accessibility

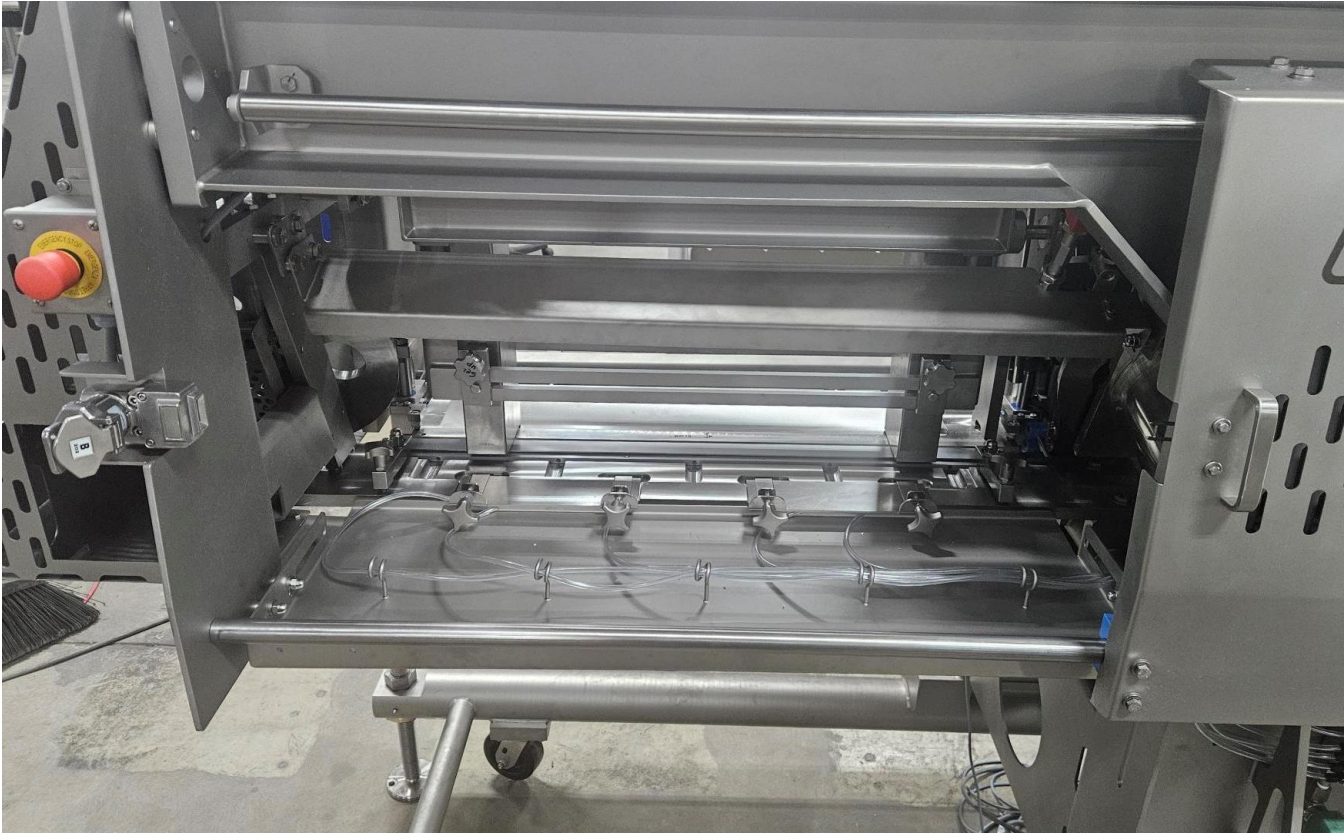

Best – New Equipment Improvements: Drive/Idle Side

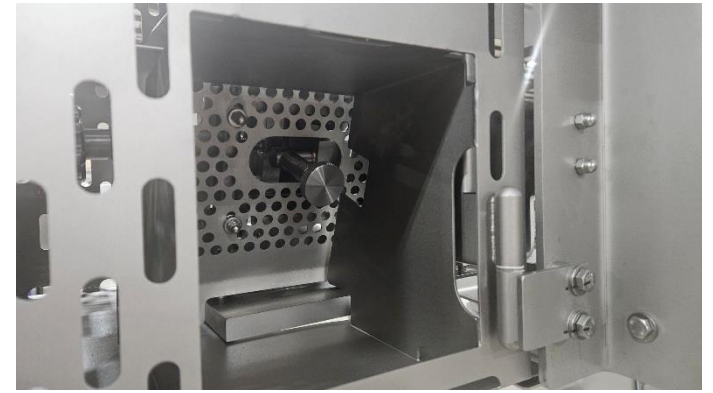
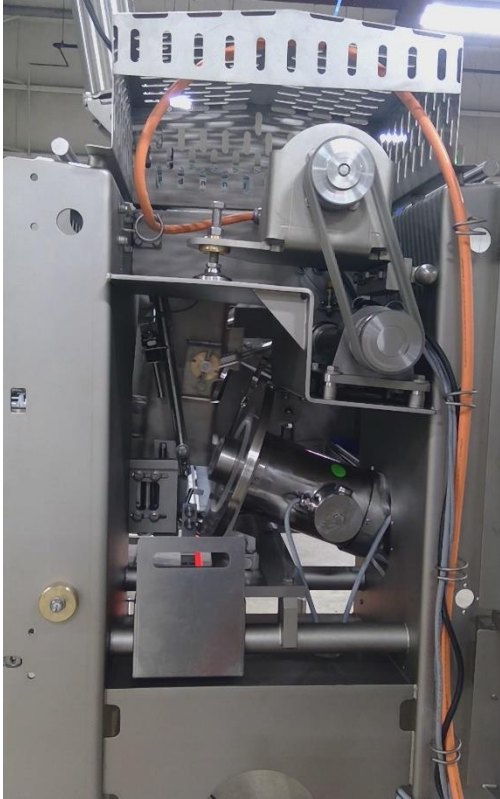

Best – New Equipment Improvements: Blade Guide



How do we improve? - Partnership

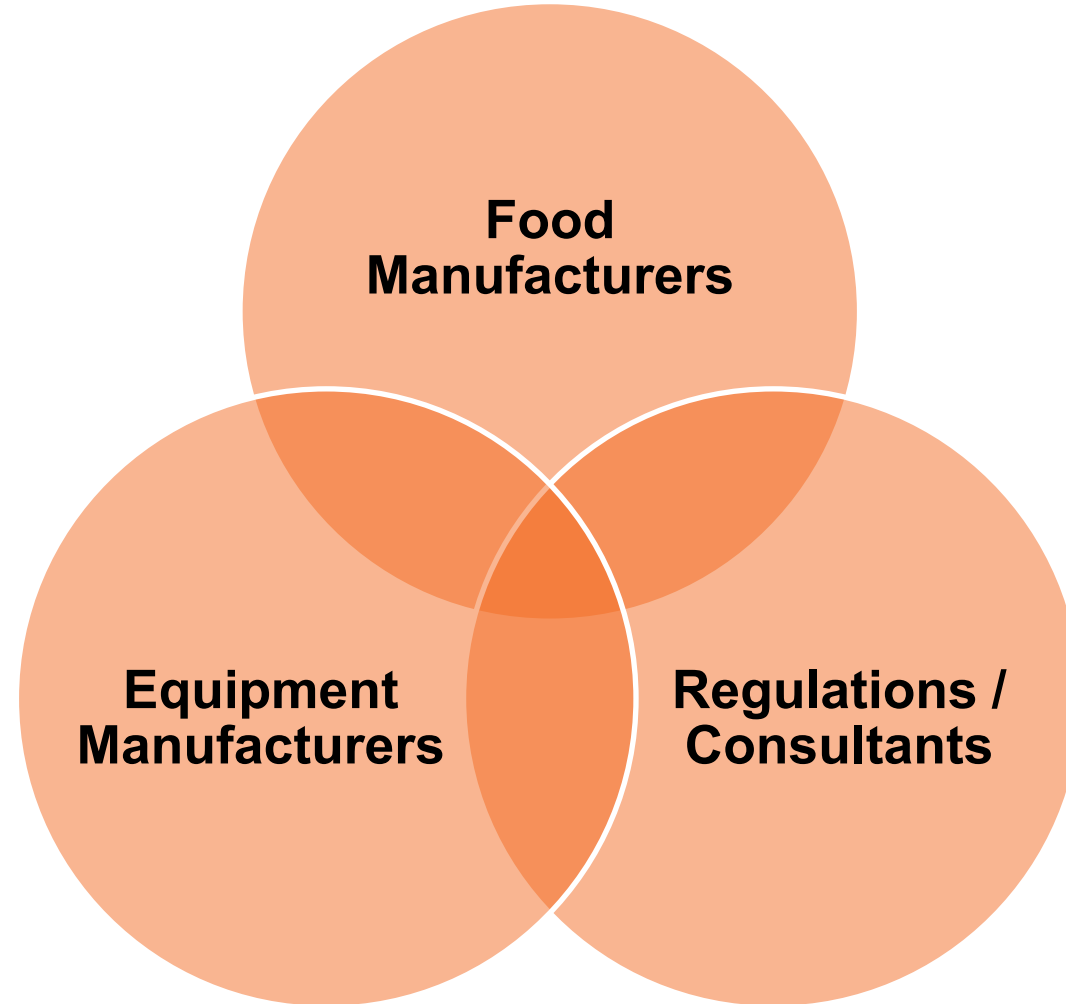

Thank You

Let's Connect & Improve Together

Brad Eley
Engineering Manager at Grote

beley@grotecompany.com

